

Projecting roof systems

Montageanleitung:
Glas-Vordach - 2051 / 2052

Installation manual:
Glass canopy - 2051 / 2052

Art. 29.2051.175.46
Art. 29.2051.250.46
Art. 29.2051.500.46
Art. 29.2052.175.46
Art. 29.2052.250.46
Art. 29.2052.500.46

Stand 10.2019

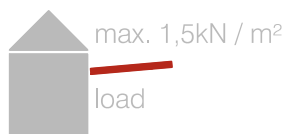
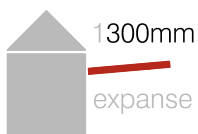
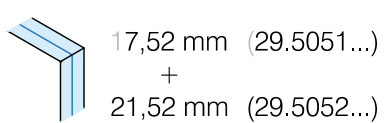
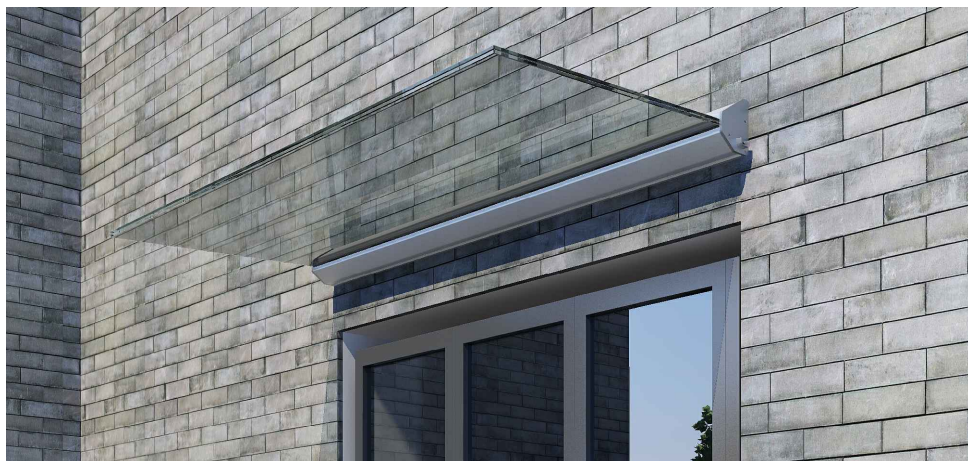

Im Lieferumfang enthalten - Scope of supply

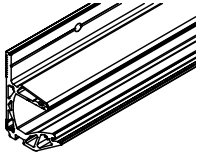
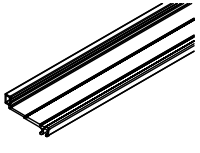
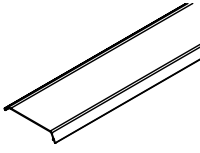
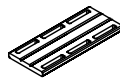
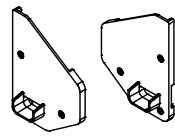
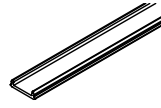
 1x	 1x	 1x	 16x (29.205x.175.46) 24x (29.205x.250.46) 40x (29.205x.500.46)	 1x	 1x (29.205x.175.46) 1x (29.205x.250.46) 2x (29.205x.500.46)
--	---	---	---	---	--

Montagewerkzeug:
Mounting tools:

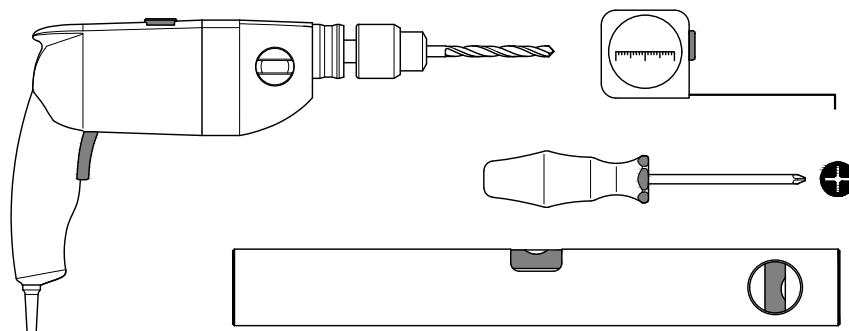

Druckfehler und technische Änderungen vorbehalten / With reservation of printing errors and technical changes.

Projecting roof systems

1.

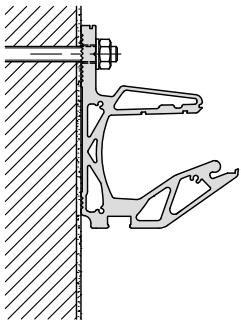

Das Basisprofil mit statisch geeignetem Befestigungs-Ankern* an der Wand befestigen. Dabei müssen alle Montage Bohrlöcher im Abstand von 250mm benutzt werden.

Falls nötig kann das Montagerohr für Außenwanddämmung auf die benötigten Längen gekürzt und montiert werden. (Art. No.: 44.1299.028.00 - nicht im Lieferumfang)

Fasten the base profile to the wall with statically suitable fixing anchors*. All mounting holes must be used at a distance of 250mm.

If necessary, the mounting pipe for external wall insulation can be shortened to the required lengths and mounted. (Art. No.: 44.1299.028.00 - not included in delivery)

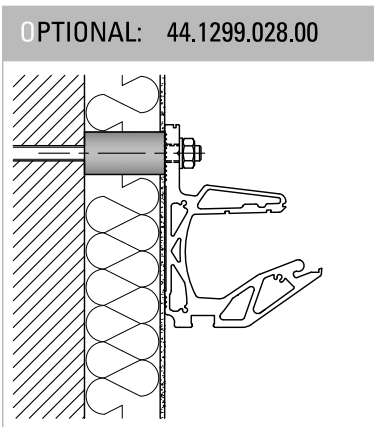
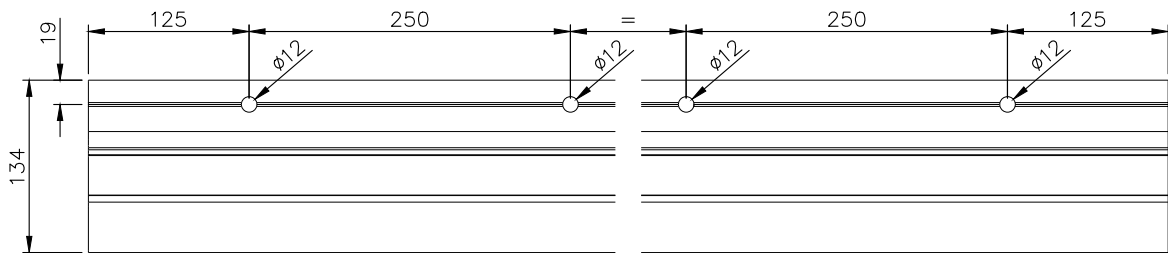

* Die Verwendbarkeit der Schrauben muss grundsätzlich vom Monteur geprüft und der Beschaffenheit des tragenden Baukörpers angepasst werden. Wir übernehmen ausdrücklich keine Haftung für Schäden die aus unsachgemäßer Montage resultieren.

* The usability of the screws must always be checked by the installer and adapted to the condition of the load-bearing structure. We expressly accept no liability for damage resulting from improper installation. Installation should only be carried out by a specialist.

2.

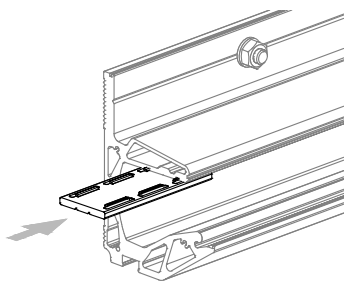
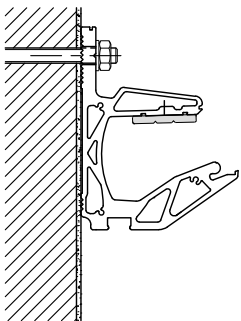

Die oberen Klemmplatten in das Basisprofil einsetzen. Die Anzahl der Klemmplatten variiert je nach Profil Länge. Abstände laut Abbildung A.

Insert the upper clamping plates into the base profile. The number of clamping plates varies depending on the profile length. Spacing according to Figure A.

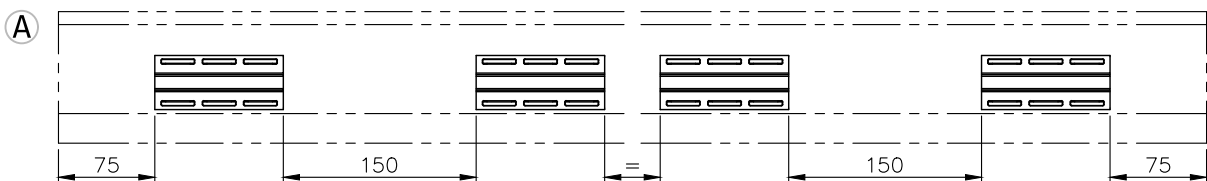

Projecting roof systems

3.

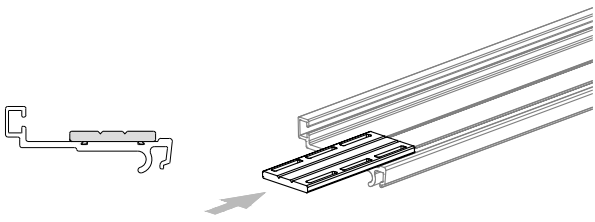

Die unteren Klemmplatten in das Klemmprofil einsetzen. Die Anzahl der Klemmplatten variiert je nach Profil Länge. Abstände laut Abbildung **B**.

Insert the lower clamping plates into the clamping profile. The number of clamping plates varies depending on the profile length. Spacing according to figure **B**.

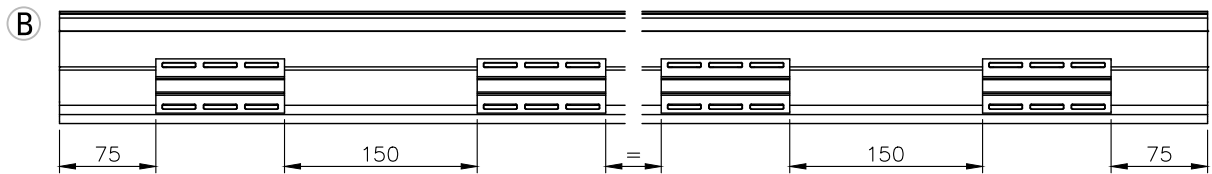

4.

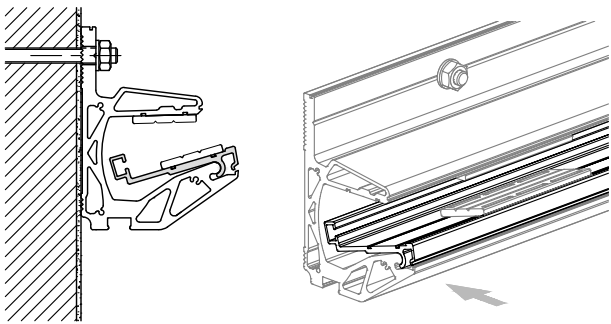

Das Klemmprofil in das Basisprofil einsetzen.
Insert the clamping profile into the base profile.

5.

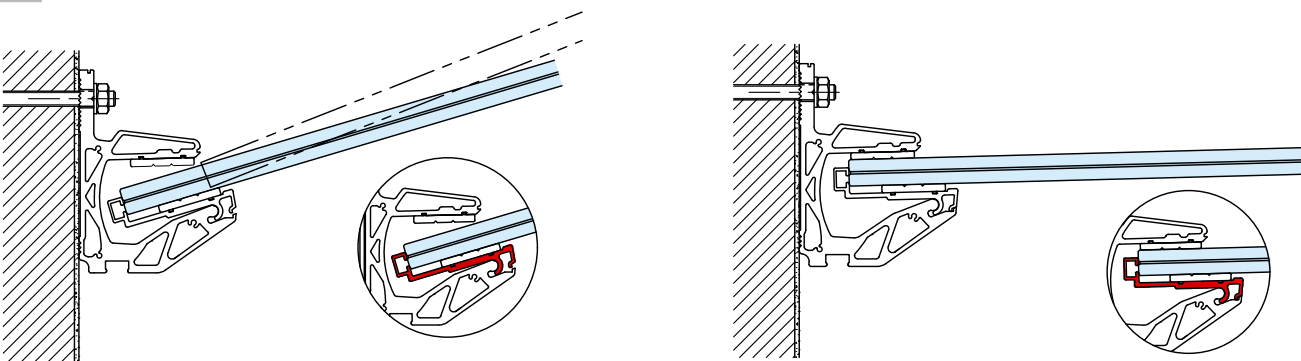

Glas Installation: Die Glasscheibe leicht angewinkelt zwischen das Basis- und das Klemmprofil führen. Das Glas muss dabei bis an die hintere Aufkantung des Klemmprofil stoßen. Danach wird das Glas langsam zurück in die horizontale Position gebracht. Bitte dabei beachten das sich das Klemmprofil mit dem Glas nach oben kippt und das Glas zwischen die oberen und unteren Klemmplatten verkeilt wird.

Glass Installation: Place the glass pane slightly angled between the base and clamping profiles. The glass must touch the rear edge of the clamping profile. The glass is then slowly returned to its horizontal position. Please note that the clamping profile with the glass tilts upwards and the glass is wedged between the upper and lower clamping plates.

Projecting roof systems

6.

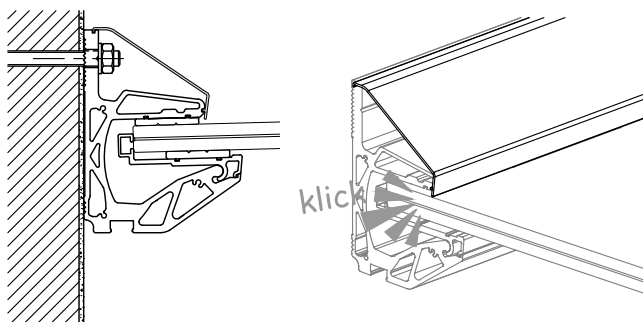

Abdeckprofil installieren: Das Profil in die obere Nut einlegen und in die untere Nut einpressen. Das Abdeckprofil ist insgesamt 10mm länger als das Basisprofil und muss an beiden Seiten 5mm überstehen.
Install the cover profile: Insert the profile into the upper groove and press it into the lower groove. The cover profile is 10mm longer than the base profile and must extend 5mm on both sides.

7.



Die Endkappen rechts und links auf das Profil stecken und mit den Schrauben befestigen. Darauf achten das sich der Sicherungszapfen der Kappe zwischen dem Basis- und dem Klemmprofil verkeilt.
Place the end caps right and left on the profile and fasten with the screws. Make sure that the locking pin of the cap is wedged between the base profile and the clamping profile.

! Wir empfehlen die gekennzeichneten Stellen mit Silikon abzudichten.
We recommend sealing the marked areas with silicon.

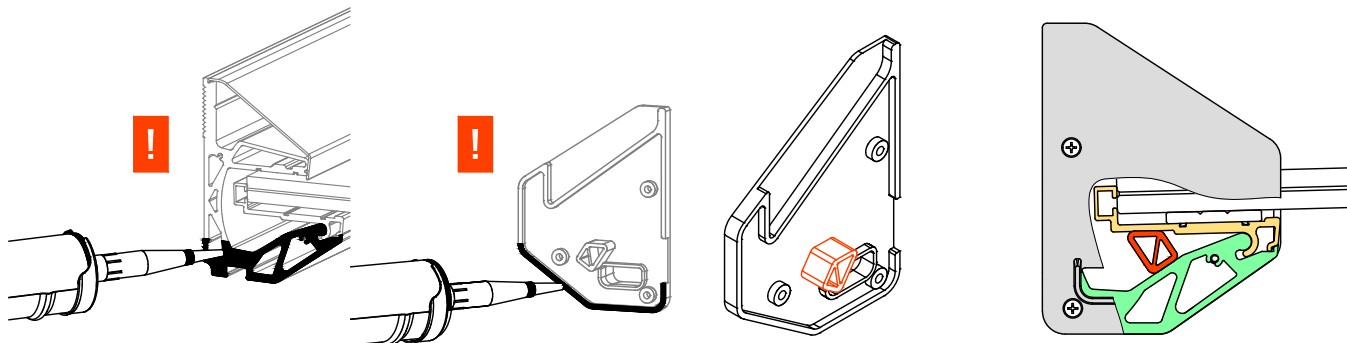

8.

